

JGX-502 Spray Gun Operation Manual

DEVILBISS

Important: Read and follow all instructions and SAFETY PRECAUTIONS before using this equipment

Description

The JGX-502 Spray Gun is a conventional air spray gun, patterned after the JGA series, whose functions are similar to standard air spray gun models. The gun is available in three types: gravity feed, suction feed, and pressure feed, in order to cover the widest range of applications.

With all areas of the fluid passages made from stainless steel, the JGX-502 can be used with a wide range of paints, with the only exception being those of a highly corrosive and/or abrasive nature. The use of such materials will require thorough cleaning and frequent part replacement.

Any questions regarding the operation of the JGX Spray Gun should be directed to us or our distributors BEFORE use.

MODELS

JGX-502 - Air Cap No. - Fluid Tip Size - Type of Feed

(Ex.): JGX-502-143-FF-G

This represents a gun with a number 143 Aircap, a Size FF Fluid Tip, and set up for Gravity Feed.

SPECIFICATIONS

Air and Fluid Inlet Threads:

Fluid	Suction/Pressure Feed PF3/8 Male, standard PF1/4 Male, Optional	
Air Inlet	PF1/4	
Weight	Suction/Pressure Feed	440g

OPERATION

Before using the gun, the needle packing, which is shipped loose to avoid binding, should be adjusted.

The packing gland (Part#7) should be gradually screwed clockwise while triggering the gun up to the point where the needle does not smoothly return to the closed-position. At this point the packing gland should be slightly loosened by screwing it in counter-clockwise so that needle moves freely.

Adjust the atomizing air pressure to the lowest level possible and commensurate with proper atomization quality desired, to minimize overspray and maximize paint transfer efficiency.

The spray gun should be used at all times perpendicular to the surface to be coated at a distance of 150-200mm.

Maintenance

The gun should be cleaned and lubricated daily to maintain its optimum performance. Clean the paint passages thoroughly by spraying solvents through the gun after use.

The gun body should never be soaked in the solvent for cleaning. Exterior surface should only be wiped with solvent dampened rags.

The air caps should be detached from the gun and soaked in the solvent.

Use toothpicks to remove any paint build up from the aircap holes. NEVER use metal objects to clean the aircaps in order to avoid damage to the fine holes, which will cause the spray pattern to become distorted.

A drop of lubricant should be applied regularly to the trigger bearing stud (#25), the stem of the air valve assembly(#21), and the needle packing gland (#7). For optimum results use SSL-10 Spray Gun Oil.

The Needle Spring (#11) and the Air Valve Spring (#22) should be lightly greased. Do not lubricate or grease excessively in order to avoid clogging in the air passages.

REPLACEMENT OF PARTS

A wrench (JGX-34) is provided with the gun.

When replacing the fluid tips, ensure that the Fluid Needle Adjustment Screw is moved, and also ensure that the Spreader Valve is in the fully open (counterclockwise) position.

Whenever the Fluid Inlet Nipple (#23) or the Air Inlet Nipple (#28) are replaced, a sealant material such as Loctite 242, should be applied to the thread before inserting it into the gun body. The same sealant should also be used on the body thread of the Spreader Valve (#13) and the Cheater Valve (#27).

Chart 1 : Aircap-Fluid Tip Combination

Aircap				Fluid Tip Size			
No. on CAP	Code	Part No.	Gun Type	GY	FX	FF	EX
103	803737	JGX-3-103	S,G	V			
146	803739	JGX-3-143	S,G		V	V	V
165	803740	JGX-3-165	P		V	V	

Chart 2 : Selection of the Fluid Tip and the Needle

Fluid Tips				Fluid Needles		Gun Type
No. on CAP	Size(mm)	Code	Part No.	Code	Part No.	
GY	0.8	803775	JGX-4-GY	803750	JGX-41-GX	S,G
FX	1.1	803786	JGX-401-FX	803751	JGX-41-FX	G,P
FX	1.1	803747	JGX-4-FX	803751	JGX-41-FX	S
FF	1.4	803787	JGX-401-FF	803752	JGX-41-FF	G,P
FF	1.4	803748	JGX-4-FF	803752	JGX-41-FF	S
EX	1.8	803749	JGX-4-EX	803753	JGX-41-EX	G,S

Notice : The fluid tip of Suction Feed gun and GY Tip (0.8m/m) is not with soft-seat.

Chart 3 : Fluid Inlet Description

Paint Supply	Thread	Code	Part No.	Remarks
S,P	PF3/8	803767	JGX-1	-----
S,P	PF1/4	803768	JGX-35	optional
G	PF1/4	803769	JGX-2	-----

PARTS LIST

#	Code	Part No.	Description	pcs	#	Code	Part No.	Description	pcs
1	803736	JGX-5	Retaining Ring	1	13	803760	JGX-44	Spreader Valve Assy.	1
	803735	JGX-6	Retaining Ring, brass(Optional)	1	17	803764	JGX-43	Air Valve Assy.	1
2		See Chart1	Air Cap	1	19*	-----	-----	Packing	1
3		See Chart2	Fluid Tip	1	20*	-----	-----	O-Ring	1
4	803741	JGX-7	Baffle	1	22	803778	JGX-25	Spring	1
5*	803783	JGX-8-K5	Gasket (a set of 5 pcs.)	1	23		See Chart3	Fluid Inlet Nipple	1
6*	803855	JGV-463	Needle Packing (2piece)	1	24	803916	JGS-108-1	Trigger	1
7	803784	JGX-11-K3	Packing Gland (a set of 3pcs.)	1	25	803567	JGX-45-K5	Bearing Stud (a set of 5pcs.)	1
8*	-----	-----	Gasket	1	26*	805281	JGX-46-K10	Circlip (a set of 10pcs.)	1
9	803745	JGX-12	Bushing	1	27	803771	JGX-42	Cheater Valve Assy.	1
10		See Chart2	Fluid Needle	1	28	803772	JGX-30	Air Inlet Nipple	1
11	803785	JGX-14-K3	Needle Spring (a set of 3pcs.)	1	29	803773	JGX-34	Wrench	1
12	803759	JGX-13	Adjusting Screw	1		803733	JGX-101	Repair Kit	1

* JGX-101 Repair Kit includes maintenance parts marked.

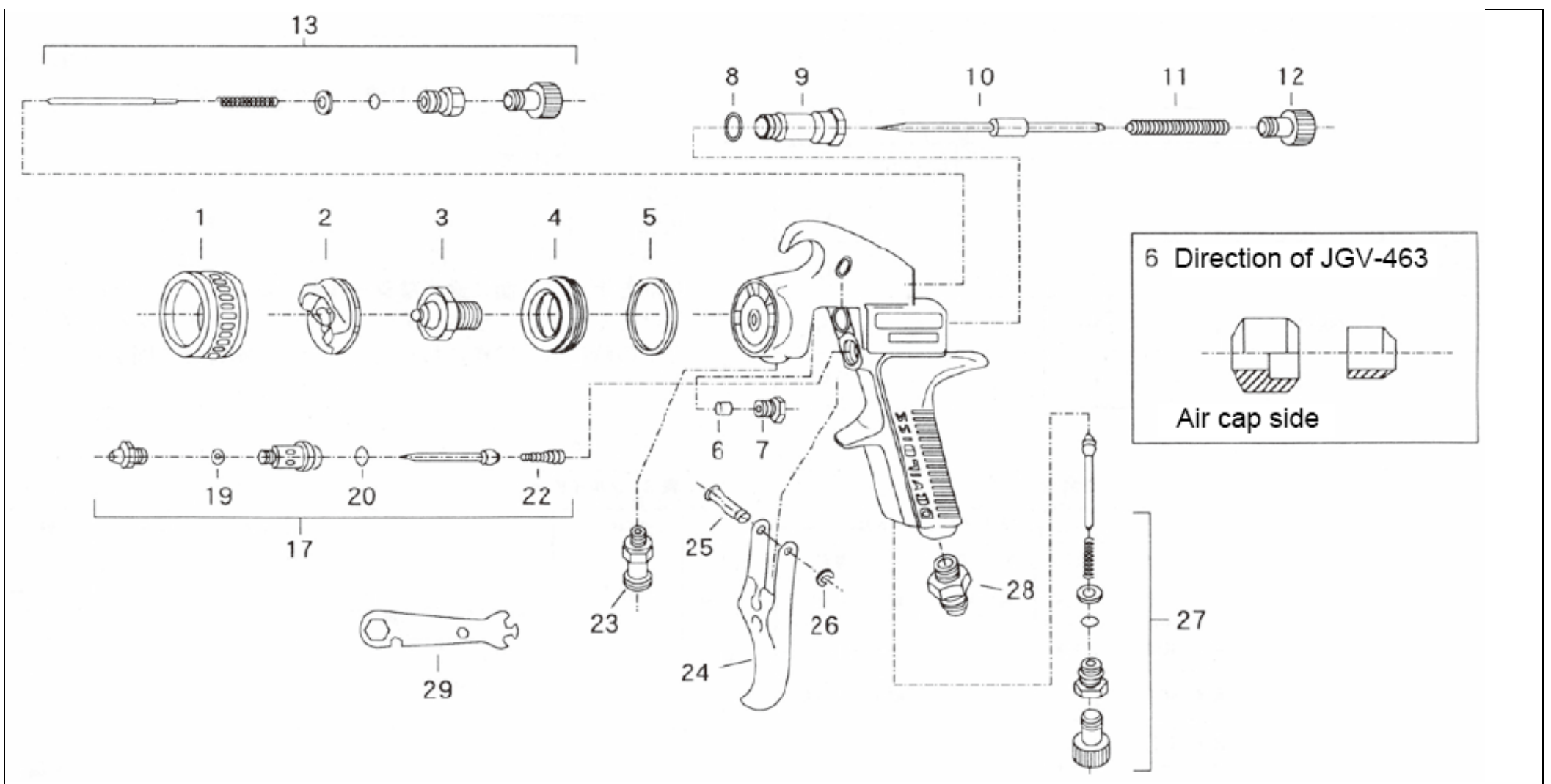

ACCESSORIES

Part No.	Description	Part No.	Description
TLC-555	1ℓ Suction Cup (with PTFE Coated Inner Lining)	HD-505-W	5ℓ Gun & Hose Cleaner
KG-400	400cc Side Cup with Stand (Gravity Feed)	JGX-101	Repair Kit
KG-400-T	400cc Side Cup with Stand (with PTFE Coated Inner Lining, Gravity Feed)	SSL-10	Spray Gun Lubricant. Silicone-free, Non-petroleum product
KB-II	KB-555 2ℓ Pressure Feed Remote Cup	HAF-507	Disposable Air Line Filter
KR-470-1	700cc Suction Cup Assembly		

DEVILBISS DIVISION

CFT Ransburg Japan KK

15-5, Fukuura 1-chome, Kanazawa-ku, Yokohama, Kanagawa Japan 〒236-0004
TEL : +81-45-785-6434 / FAX : +81-45-785-6517

HP <http://www.carlisleleft.co.jp>

©DEVILBISS is a registered trademark of Carlisle Fluid Technologies
©Jupiter is a registered trademark of CFT Ransburg Japan KK.



©2017 Carlisle Fluid Technologies.

2017-07- JGX-502